



Mounting aid

MHW 06

- Suitable for VariKont and VariKont L sensors
- Aluminum profile, pre-mounted
- For mounting on support profiles in conveying technology (available for different types of profiles)
- Simple and fast mounting
- Sensor position adjustable in all 3 axial directions
- Sensor can be mounted length or crosswise on the profile section
- All fixing components are provided with captive screws

Modular mounting bracket

Dimensions

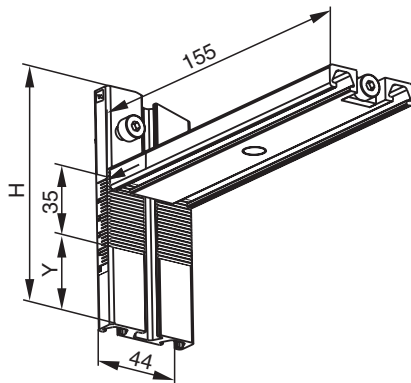

Technical Data

Mechanical specifications

Material	Extruded aluminum profile
Dimensions	Profile rail 1 for the installation of the mounting bracket: 155 mm Profile rail 2 for positioning the mounting bracket for the supporting profile: [*PD-Z02209A*]

Release date: 2020-03-20 Date of issue: 2020-06-29 Filename: 106175_eng.pdf

Refer to "General Notes Relating to Pepperl+Fuchs Product Information".

Pepperl+Fuchs Group
www.pepperl-fuchs.com

USA: +1 330 486 0001
fa-info@us.pepperl-fuchs.com

Germany: +49 621 776 1111
fa-info@de.pepperl-fuchs.com

Singapore: +65 6779 9091
fa-info@sg.pepperl-fuchs.com

PF PEPPERL+FUCHS

Mounting

Installation

- Position the sliding block on the serrated side of profile rail 1 in the centre slot of profile rail 2.
- To form the mounting bracket, position the profiles at right angles to each other, by engaging the serrations.
- Stabilise the mounting bracket by tightening the cylindrical head screw on the end.
- Place the mounting bracket on the surface of the supporting profile (A) and twist the bracket by its ends (B) until it engages behind the flanges in the supporting profile.
- Align the mounting bracket.
- Secure the profile rail on the supporting profile by means of the clamping screw (C).
- Insert the two M5 x 18 screws (for VariKont Sensors) or M5 x 42 (for VariKont L Sensors) in the base of the sensor and pre-mount the sliding blocks.
- Insert the sliding blocks into the two grooves in the profile rail 1.
- Position the sensor as required and clamp it.

Note:

With some applications the installation is easier if the sensor is pre-mounted on the profile section before the mounting bracket is assembled and mounted on the supporting profile.

Scope of Delivery

Supplied accessories

Modular mounting bracket MHW ..., consisting of

- 1 profile rail 1 (155 mm) for installation of the mounting bracket, pre-mounted with clamp, clamping plate, sliding block and cylindrical head screw (M6 x 155/DIN 912)
- 1 profile rail 2 (length H) for positioning the mounting bracket on the supporting profile, pre-mounted with sliding block and cylindrical head screw (M6 x 20 / DIN 912)
- 2 sliding blocks (M5) for the installation of the sensor
- 2 cylindrical head screws (M5 x 18/DIN 84) for VariKont Sensors
- 2 cylindrical head screws (M5 x 42/DIN 84) for VariKont L Sensors

Mounting

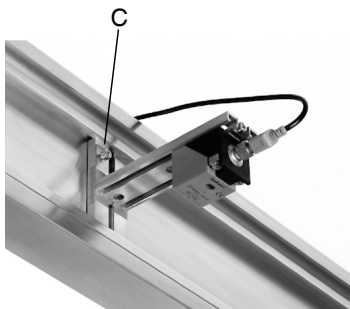

VariKont L installed on the

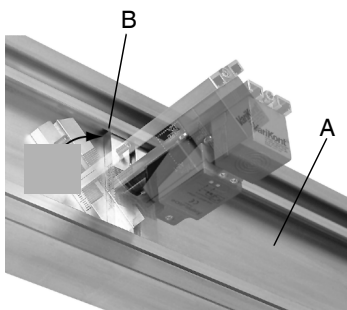

Installation of the mounting bracket on the supporting